

PCT

WORLD INTELLECTUAL PROPERTY ORGANIZATION
International Bureau



INTERNATIONAL APPLICATION PUBLISHED UNDER THE PATENT COOPERATION TREATY (PCT)

<p>(51) International Patent Classification ⁵ : B01D 57/02, G01N 27/26 B01L 3/00</p>	<p>A1</p>	<p>(11) International Publication Number: WO 91/16966 (43) International Publication Date: 14 November 1991 (14.11.91)</p>
<p>(21) International Application Number: PCT/SE91/00327 (22) International Filing Date: 8 May 1991 (08.05.91) (30) Priority data: 10 May 1990 (10.05.90) SE 9001699-9</p>	<p>(74) Agents: WIDÉN, Björn et al.; Kabi Pharmacia AB, S-751 82 Uppsala (SE). (81) Designated States: AT (European patent), BE (European patent), CH (European patent), DE (European patent), DK (European patent), ES (European patent), FR (European patent), GB (European patent), GR (European patent), IT (European patent), JP, LU (European patent), NL (European patent), SE (European patent), US.</p>	
<p>(71) Applicant (for all designated States except US): PHARMACIA BIOSENSOR AB [SE/SE]; S-751 82 Uppsala (SE). (72) Inventors; and (75) Inventors/Applicants (for US only): EKSTRÖM, Björn [SE/SE]; Järpvägen 27, S-752 52 Uppsala (SE). JACOBSON, Gunilla [SE/SE]; Spetsvägen 20, S-752 57 Uppsala (SE). ÖHMAN, Ove [SE/SE]; Björkgatan 43, S-752 24 Uppsala (SE). SJÖDIN, Håkan [SE/SE]; Lindsbergsgatan 3 B, S-752 40 Uppsala (SE).</p>		<p>Published With international search report.</p>

(54) Title: MICROFLUIDIC STRUCTURE AND PROCESS FOR ITS MANUFACTURE

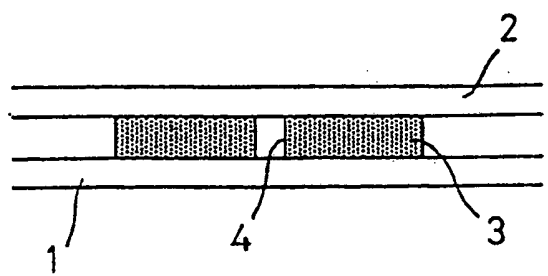

(57) Abstract

A microfluidic structure comprises first and second substantially planar form-stable base layers (1, 2), and an intermediate spacing layer (3) of elastic material, said spacing layer (3) being recessed to define a microcavity or channel system (4) with at least one of said first and second base layers. The structure is produced by moulding the spacing layer, optionally applied to or integral with a first base layer (2), against a planar mould, and the microcavity or channel system is completed by applying a second base layer (1), and optionally said first base layer (2), to the spacing layer (3).

FOR THE PURPOSES OF INFORMATION ONLY

Codes used to identify States party to the PCT on the front pages of pamphlets publishing international applications under the PCT.

AT	Austria	ES	Spain	MG	Madagascar
AU	Australia	FI	Finland	ML	Mali
BB	Barbados	FR	France	MN	Mongolia
BE	Belgium	GA	Gabon	MR	Mauritania
BF	Burkina Faso	GB	United Kingdom	MW	Malawi
BG	Bulgaria	GN	Guinea	NL	Netherlands
BJ	Benin	GR	Greece	NO	Norway
BR	Brazil	HU	Hungary	PL	Poland
CA	Canada	IT	Italy	RO	Romania
CF	Central African Republic	JP	Japan	SD	Sudan
CG	Congo	KP	Democratic People's Republic of Korea	SE	Sweden
CH	Switzerland	KR	Republic of Korea	SN	Senegal
CI	Côte d'Ivoire	LI	Liechtenstein	SU	Soviet Union
CM	Cameroon	LK	Sri Lanka	TD	Chad
CS	Czechoslovakia	LU	Luxembourg	TG	Togo
DE	Germany	MC	Monaco	US	United States of America
DK	Denmark				

TITLE

MICROFLUIDIC STRUCTURE AND PROCESS FOR ITS MANUFACTURE

FIELD OF THE INVENTION

5 The present invention relates to an improved
microfluidic structure which may find use in various fields
of application such as various electrophoretic procedures,
capillary chromatography, liquid distribution systems and
the like, as well as to a process for the manufacture
10 thereof.

BACKGROUND OF THE INVENTION

A recent development of electrophoretic technique is
~~capillary electrophoresis. As with conventional methods of~~
electrophoresis charged molecules may be isolated and
15 determined in an electric field based upon their relative
mobilities. A capillary electrophoretic system basically
consists of a fused silica capillary having an inner
diameter of approximately 25 to 100 microns and which
connects two reservoirs filled with buffer. Separation
20 takes place in the buffer filled capillary and substances
may be detected by UV absorbance or emitted fluorescence by
means of a concentrated transverse beam of light passing
through the capillary.

In relation to conventional gel electrophoresis the
25 use of a capillary system permits a considerably higher
electric field strength due to reduced generation of heat
and an improved cooling effect (reduced ratio of cross-
sectional to circumferential area). This results in very
fast separations with extremely high resolution.

30 Drawn glass capillary tubes have, however, several
disadvantages. Among those may be mentioned the difficulty
of providing branched systems as well as the difficulty of
creating areas having particular surface characteristics.
It is also relatively difficult to manufacture extremely
35 small bore glass tubes. Further, glass capillaries are also
unsuitable for parallel channel analyses and only small
volumes can therefore be separated, separations for
preparative purposes thereby being impractical.

To overcome these disadvantages planar structures have been developed in which a number of trenches or channels are fabricated in parallel. Typically, such a planar structure is produced by etching trenches in a semiconductor substrate, such as a silicon wafer, and then covering the etched surface by a cover plate to complete the electrophoretic channels. Such structures are, however, rather expensive to produce. Further, since the materials used are rigid and hard, it is difficult to provide an adequate sealing between the top edges of the etched trenches and the cover plate. As the etched substrate is most often a semiconductor, the material per se is unsuitable for electrophoretic applications and the channel side-walls must therefore be provided with an insulating surface layer, such as by oxidation or by coating with some other material.

SUMMARY OF THE INVENTION

An object of the present invention is to provide a microfluidic structure suitable for capillary electrophoresis and which is devoid of the above disadvantages and thus is relatively cheap to produce, optionally permitting a disposable type product, may provide branched flow channels, may exhibit local surface characteristics, and provides great freedom in choice of material, e.g. as regards surface, optical and electric properties.

Another object of the present invention is to provide a microfluidic structure which, in addition to capillary electrophoresis, is suitable for other applications such as capillary chromatography, procedures using micro reaction cavities, miniaturized liquid communication units etc.

Still another object of the present invention is to provide a microfluidic structure in the form of a multi-storey construction having channels or cavities in several planes to thereby permit the build-up of complex channel or cavity geometries for analyses or reactions.

Another object of the present invention is to provide a microfluidic structure which permits easy detection of substances in the flow system.

A further object of the present invention is to
5 provide a process for the manufacture of the above microfluidic structure.

Thus, in one aspect the present invention relates to a microfluidic structure comprising first and second
10 substantially planar base layers of a form-stable material, and an intermediate spacing layer of elastic material, said spacing layer being recessed to define a micro cavity or channel system with at least one of said first and second
15 base layers.

In another aspect the present invention provides a
15 process for the manufacture of such a microfluidic structure, which process comprises the steps of providing a mould having a planar face with a relief pattern corresponding to the desired spacing layer geometry,
20 including said liquid flow system, applying and moulding a spacing layer material against the mould surface, optionally together or integral with a superposed first base layer, removing the mould from the shaped spacing layer, applying a second base layer to the shaped surface
25 of the spacing layer to complete the liquid flow system therewith, and, if not done previously, applying said first base layer to the opposite surface of the spacing layer.

BRIEF DESCRIPTION OF THE DRAWINGS

The above objects, features and advantages will be apparent from the following description and the appended
30 claims, taken in conjunction with the accompanying drawings, in which:

Fig. 1 is a plan view of an embodiment of a capillary electrophoretic plate according to the present invention;

Fig. 2 is a plan view of one of the base layers of the
35 structure in Fig. 1 including detector and electric contact means;

Fig. 3 is a plan view of the other base layer of the structure in Fig. 1 supporting a spacing layer defining an upwardly open liquid channel;

Fig. 4 is a partial cross-sectional view of the structure in Fig. 1;

Fig. 5 is another embodiment of capillary electrophoretic plate according to the present invention;

Fig. 6 is a schematic illustration of the manufacture of a number of base layer/spacing layer assemblies corresponding to that in Fig. 3;

Fig. 7A is a schematic cross-sectional view of a sandwich structure comprising three superposed spacing layers with intermediate base layers, and Fig. 7B is a cross-sectional view of one base layer/spacing layer assembly used to build up the sandwich structure;

Fig. 8 is a partial cross-sectional view of a structure comprising integral spacing and base layers;

Fig. 9 is a partial cross-sectional view of the structure shown in Fig. 8 placed in a clamping means;

Fig. 10 is a schematic view of another embodiment of base layer including an ion exchanger strip; and

Fig. 11 is a diagram showing the result of an electrophoretic procedure performed with a capillary electrophoretic plate of the invention.

25 DETAILED DESCRIPTION OF THE INVENTION

In its simplest form the microfluidic structure according to the present invention consists of two base layers between which an elastic spacing material, which is firmly attached to at least one of the base layers, forms a geometric micro structure defining the desired liquid flow system, e.g. one or more cavities or a labyrinth-like channel.

For the provision of the liquid flow system the spacing layer may be recessed through a part or the whole thickness thereof. In the first case the spacing layer forms the side walls and one of the top and bottom walls of each cavity or channel, one of the base layers forming the other of the top and bottom walls, whereas in the latter

case the base layers form the top and bottom walls and the spacing layer forms the side walls. Due to the elasticity of the spacing layer adequate sealing thereof to the respective base layer(s) is obtained.

5 In a development thereof the structure of the invention consists of a "multi-storey" sandwich structure having two or more spacing layers separated by base layers, ~~the liquid flow systems in adjacent spacing layers~~ communicating by apertures or bores in the intermediate
10 base layers. In this way e.g. complex flow channel systems may be formed. Such a multi-storey structure may be formed by piling several base layer/spacing layer assemblies on top of each other.

The base layers should be form-stable, which term,
15 however, herein is to be understood in a relatively broad sense as will be further elucidated below. Therefore, not only non-elastic materials but also moderately elastomeric materials may be contemplated as will readily be appreciated when considering the below stated purpose of
20 and requirements on the base layers. Thus, the purpose of the base layers is, on one hand, to support the spacing layer as well as to form part of the channel or cavity walls, and on the other hand to maintain and ensure the dimensions of the structure in the XY-plane thereof; the
25 XY-plane is that of the base layer plane extension, and Z is the direction perpendicular thereto. Form-stable therefore refers to a material that will give only small and well defined dimensional changes under conditions dictated by the particular application. The base layer
30 surface should have a good surface smoothness to ensure efficient sealing under moderate pressures. This may be implemented, for example, by the base layer being stiff or by using a flexible film placed on a planar and possibly elastic surface. As suitable materials for the base layer,
35 which may be in plate, sheet, foil or film form, may be mentioned glass, metal or plastic, such as polyester, polyethylene terephthalate, e.g. Mylar, fluoroplastic, e.g. Hostafilon. The above mentioned apertures in the base layer,

necessary for e.g. sandwich applications, may be accomplished by high precision techniques such as laser drilling or numerically controlled precision machinery.

As mentioned above the purpose of the spacing layer is to build up the side walls of the channels or cavities and provide for the desired elasticity in the Z-direction, i.e. perpendicularly to the plane extension. The material should thus be elastic, i.e. preferably be a rubber or an elastomer. An example of a suitable type of material is

5
10

silicone rubber. Other specific examples are EPDM rubber and Hostafilon. Depending upon the method used for the manufacture of the base layer/spacing layer assembly, which will be described in more detail below, the spacing layer

material should also have satisfactory properties as a moulding material, such as low viscosity and form shrinkage, a suitable curing or hardening principle, e.g. UV-light or other radiation, temperature, etc, as well as a suitable hardness to provide for efficient sealing. The above properties makes it possible to transfer and multiply with great accuracy the exact geometry from precision-made moulds or dies to cheap polymeric materials. Such high precision moulds or dies may, for example, advantageously be fabricated by etching in single crystal materials, as will be described below. As mentioned previously, the

15
20
25

elastic or resilient properties of the spacing layer or layers permit a very good sealing between base and spacing layers, or between adjacent spacing layers, to be obtained. The spacing layer (when stabilized) should preferably also have surface properties providing for suitable surface

30

characteristics when joined to a base layer and defining a cavity or channel therewith, e.g. hydrophobic-hydrophobic interaction for applications involving aqueous solutions.

Concerning the basic structure of the invention consisting of two base layers and an intermediate spacing layer, it is readily realized, however, that there are materials that will satisfy at the same time the requirements on both the base layer and the spacing layer. The spacing layer and one or both of the base layers may

35

then be made of the same material. In such a case the spacing layer and one base layer may also be integral as will be further described below. The above described multi-storey structure may, of course, also be made up from such
5 integral base layer/spacing layer units. An example of a material that may be used in this respect is Hostafilon.

Preferably, the spacing layer does not fill the whole space enclosed by the two base layers, but only to the extent to provide for sufficient wall thicknesses of the
10 channels or cavities defined thereby. Thus, for e.g. a winding channel the spacing layer material defining it will exhibit the same winding geometry but with a wider cross-section. ~~In this way inter alia a smaller sealing area is~~
obtained, thereby requiring a lower total sealing force to
15 be applied for a given surface pressure.

The elasticity of the spacing layer(s) may also be used to give the structure the function of a pump or valve by variation of a force acting in the Z-direction, i.e. normally to the base and spacing layer planes. The force
20 required to compress the structure to obtain such a pumping action will also be lower the more reduced the spacing layer extension is, as just discussed above.

As stated hereinbefore the required recessing of the spacing layer is, in accordance with the invention,
25 accomplished by forming the spacing layer against a planar mould, e.g. a sheet or plate, which has a moulding surface provided with a relief pattern being the negative of the desired geometric structure to be exhibited by the spacing layer. Such a mould may, for instance, be produced by
30 etching, surface coating, laser processing, electrochemical etching, mechanical processing, or combinations thereof, of a substrate of, for instance, silicon, quartz, ceramic, metal or plastic material, e.g. PMMA or Teflon[®]. The mould used for forming the spacing layer may, of course, very
35 well be a replica of an originally manufactured master mould produced therefrom by casting or moulding.

The preferred method of producing such a mould involves etching. The material of choice is then a single

crystalline material, like e.g. silicon or quartz, or various group III/V materials, such as e.g. gallium arsenide, i.e. a material which has such a structure/composition that a well-defined surface will be produced by chemical processing in gas or liquid phase, and which has such mechanical/thermal properties that it will withstand the pressures and temperatures required by such forming process. A preferred material is single crystalline silicon.

10 The etching of a desired relief pattern on the surface may be effected in a manner known per se, i.e. by providing the substrate with an etch stopper layer (usually by oxidation), ~~coating with a photosensitive layer~~

(photoresist), exposing the surface through a mask defining the desired relief pattern, and developing the exposed areas to remove the photoresist therefrom, and then opening the bared etch stopper layer in those areas, removing the remaining photoresist mask, and finally etching the bared substrate surface areas to the desired depth.

20 The moulding of the spacing layer may be performed in various ways. Thus, for instance, in one embodiment the spacing layer is formed by a compression moulding type procedure, involving impression, or coining or embossing, of the spacing layer material. In this case the spacing layer material, optionally attached to or integral with a base layer, is applied against the mould surface, and the assembly is pressed together by an external force. In case the material is thermoplastic, the viscosity thereof is lowered by increasing the temperature, and the spacing layer relief pattern formed is then made permanent or stabilized by lowering the temperature. Other ways of stabilizing the spacing layer includes cross-linking thereof, e.g. by UV-radiation, a catalyst, heat, etc. In the latter case the spacing layer material may be a thin layer of a cross-linkable liquid, such as a silicone rubber, coated on the surface of the base layer.

In another embodiment the spacing layer is formed by an injection moulding type procedure. In this case the base

layer is applied against the mould surface, and the base layer and the mould are pressed together by an external force. A cross-linkable liquid, e.g. a silicone rubber, is then pressed into the mould cavity formed, whereupon it is cross-linked by appropriate cross-linking means, such as UV-light. Alternatively, a thermoplastic polymer melt might be injected to form the spacing layer when stabilized by cooling.

When the hardening or stabilization of the spacing layer is completed, the base layer/spacing layer assembly is removed from the mould. In order to facilitate the release of the formed spacing layer from the mould, the latter is preferably treated with a release agent prior to the moulding operation, e.g. a fluorotenside in liquid phase or a fluoropolymer in gaseous phase.

After removal from the mould the second base layer is applied to the spacing layer to complete the desired cavity or channel system. Optionally this second base layer is covalently or otherwise bound to the spacing layer by suitable means as will be discussed in more detail below.

In order to achieve optimum sealing between the spacing and base layers, the assembly thereof is, at the time of use for the particular application, placed in a clamping means between planar faced clamp members capable of exerting a compressive force on the assembly. Such a clamping means may also be used to make the assembly perform the above mentioned pumping action.

For electrophoretic purposes the second base layer is advantageously provided with contact means, e.g. gold strips, at each end thereof, as well as detector means or at least provisions therefor. In such a case this second base layer is preferably made reusable, whereas the first base layer with attached spacing layer is of disposable type and separable from the second base layer such that after use the latter may readily be provided with a new base layer/spacing layer assembly.

As mentioned above the microfluidic structure of the invention may, of course, advantageously also be designed

for other microfluidic purposes than electrophoresis. Among those are e.g. capillary chromatography, micro-reaction cavity procedures, miniaturized liquid communication units, biosensor flow cells, etc. Reaction cavities constructed in accordance with the invention may, for example, be used for various forms of solid phase synthesis, such as peptide or oligonucleotide synthesis, PCR, DNA-solid phase sequencing reactions, just to mention a few.

Fig. 1 illustrates a capillary electrophoretic plate according to the present invention. It consists of a first base layer 1, a second base layer 2, and an elastic spacing layer 3 disposed between the two base layers 1, 2. The spacing layer 3 is recessed to define a channel 4. For illustrative clarity only, the base layer 2 is here made transparent (Figs. 1 and 3).

The base layer 1 is made of a form-stable, i.e. non-elastic or moderately elastic, material, for instance glass, and is at each end portion thereof provided with electrode strips 5, 6, e.g. of gold film. In the illustrated case the base layer 1 is also provided with a conductivity detector means 7 in the form of a pair of e.g. gold electrodes 8, 9 arranged to cross the channel 4 and extending from contact pieces 10, 11, e.g. also of gold, on either side of the base layer.

The elastic spacing layer is attached to the second base layer 2, e.g. a polyester film, as shown in Fig. 3. In the illustrated case the spacing layer 3 is a labyrinth-like structure having the channel 4 recess therethrough. In Fig. 3 the spacing layer 3 is attached to the bottom side of the base layer 2, and the channel 4 is therefore open downwardly, whereas the top wall thereof is formed by base plate 2. The spacing layer 3 may, for example, be made of silicone rubber.

The capillary electrophoretic plate as shown in Fig. 1 is formed by applying the base layer/spacing layer assembly of Fig. 3 to the base layer 1. Due to the elasticity of spacing layer 3 efficient sealing against the base layer 1 is obtained. By matching the surface properties, the

importance of which has been mentioned above, sufficient adhesion between base layer 1 and spacing layer 3 for them to stick together will be obtained. For certain material combinations gluing may, however, be necessary.

5 In a specific non-limiting example, with particular reference to the electrophoretic plate in Fig. 1, the base layer is of glass and has a length of 60 mm, a width of 20 mm and a thickness of about 0.5 mm. The spacing layer 3 is made of silicone, General Electric 670 (General Electric
10 Company), with a hardness of 90 shore and has a width of 1 mm. The length of channel 4 defined thereby is 100 mm and its width 250 microns. The channel depth, i.e. the ~~thickness of the spacing layer, is 50 microns and the~~
15 volume is 1.25 microlitres. The electrodes 8, 9, which may be of gold, have a width of 50 microns and a spacing of 50 microns. The base layer 2, which is of polyester, is 12 x 40 mm and has a thickness of about 0.2 mm.

To perform an electrophoretic separation with the capillary electrophoretic plate shown in Fig. 1 it is
20 placed between two flat surfaces and an appropriate force is applied to hold the plate sandwich sealingly together. The channel 4 is filled with electrophoretic buffer by applying a liquid drop at one end and sucking it into the channel by means of vacuum. Sample is then applied to the
25 channel, optionally by using the resilient structure as a pump or by an enriching ion exchanger zone as will be described below. Buffer soaked filter paper pieces, indicated in Fig. 1 with dashed lines and designated by reference numerals 12, 13, are applied to the respective
30 ends of channel 4 to provide contact between the channel and the contact strips 5, 6, and the electrophoresis voltage from an external source is applied. The separation process is monitored by the detector 7.

Fig. 5 illustrates a variation of the capillary
35 electrophoretic plate in Fig. 1. In this shown embodiment the channel 4 is closed at each end, and instead the channel opens into apertures 14, 15 made in the upper base layer 2a supporting the spacing layer. There are further no

contact strips on the lower base layer, here designated by reference numeral 1a. The buffer may be supplied by e.g. a respective small buffer filled container placed above each aperture 14, 15, into which containers electrodes are
5 immersed for applying the external voltage field.

The spacing layer 3 may, for example, be produced by applying base layer 2 against a planar mould having a relief pattern corresponding to the labyrinth-like spacing layer structure including channel 4. The silicone material
10 is then injected into the mould cavity and the spacing layer formed is subsequently cured by UV irradiation. After removal from the mould the spacing layer 3 supported by the base layer 2 is as shown in Fig. 3.

A schematic illustration of the production of a
15 plurality of base layers 2 with attached spacing layers 3 as outlined above, e.g. of the materials and dimensions given hereinbefore as a specific example, is represented in Fig. 6. This figure is intended to illustrate a mould surface having a pattern of grooves 16 corresponding to
20 seven spacing layers 3 arranged side by side.

A mould plate exhibiting the desired mould pattern may, for example, be produced as follows:

The surface of a silicon plate is oxidized in an oven at 1100 °C to form an oxide layer of a sufficient
25 thickness, e.g. about 8000 Å. After washing, dehydration in an oven and priming with hexamethylsilane, a photoresist layer is applied by spinning and stabilized by baking. A mask corresponding to the desired groove pattern is then placed upon the plate surface, and the non-covered portions
30 are subjected to light exposure. The exposed photoresist portions are removed by developer solution to bare the oxide layer, and the remaining photoresist mask is hard-baked. The bared oxide is then etched with hydrofluoric acid/ammonium fluoride to expose the silicon (the back-side
35 of the plate being protected, such as by resistant tape) and the photoresist mask is removed by a suitable solvent, such as acetone. The oxide-free silicon areas are then etched by potassium hydroxide solution for a sufficient

time to produce the desired depth. The resulting mould surface will exhibit the desired pattern of grooves 16.

To produce the base layer/spacing layer unit 2, 3, a film or sheet of e.g. polyester (here represented as being transparent) is placed upon the mould surface, preferably after having treated the mould surface and film with a release agent. Pressure is then applied, e.g. 4 bars of compressed air, and a cross-linkable liquid, such as silicone rubber (e.g. RTV 670 supplied by General Electric Company) is introduced through the inlet 17 until it emerges at outlet 18. After photo-curing by UV light the base layer sheet is removed from the mould and cut into separate base layer sections (each forming a base layer 2) along lines 19, if not already done prior to application to the mould. Reference numeral 20 indicates transverse stop stripes (not shown in Fig. 1) to prevent buffer in filter papers 8, 9 in Fig. 1 from entering the structure beside the channel.

The structure shown in Fig. 3, consisting of base layer 2 and the spacing layer 3 supported thereby, may be used to build up multi-storey structures as is schematically illustrated in Fig. 7A showing three superposed spacing layer/base layer assemblies according to Fig. 7B. In such manner very complex channel geometries for reactions and analyses may be constructed. The channels of adjacent spacing layers 3 may be connected by bores in the respective base layers, the channel ends then being closed as in base layer 2a in Fig. 5.

In the electrophoretic plate shown in Figs. 1 and 5 the smaller base layer 2, 2a with attached spacing layer 3, which advantageously is of disposable type, may easily be torn off from the larger base layer 1 provided with detector means 7, whereupon a new base layer/spacing layer assembly 2, 3 may be applied to the base layer 1 which is the more expansive one of the two components.

With reference to the above described structure, and particularly to Fig. 4, the spacing layer 3 and one of the two base layers 1, 2 may be integral, i.e. produced as an

integral member from one and the same material. This is schematically illustrated in Fig. 8 wherein reference numeral 21 represents an integral base layer/spacing layer member defining a channel 22, and 23 indicates a second base layer.

The embodiment illustrated in Fig. 8 may e.g. be produced as follows:

A silicon mould plate having the desired relief pattern is first produced as described above, either for a single spacing layer or, preferably, for a plurality of spacing layers as in Fig. 6. A 300 - 500 μm Hostafilon film (Hostafilon is a thermoplastic fluoroelastomer supplied by ~~Hoechst AG, Germany~~) is then applied to the silicon mould surface, optionally after applying a release agent, and a smooth silicon plate, i.e. without any relief pattern, is applied thereabove to sandwich the Hostafilon film between them. Gold coatings are then applied to the outer surfaces of the respective silicon plates. The sandwich is then placed in a pressing means, a pressure (10-50 kg/cm^2) is applied and the gold coatings are connected to a voltage source to electrically heat the sandwich to about 150°C. Hereby the Hostafilon film softens and the mould surface pattern is impressed or coined into the plastic film. The voltage source is then disconnected, and the sandwich is allowed to cool. Upon removal from the mould, the resulting base layer/spacing layer unit has a cross-section corresponding to that schematically illustrated in Fig. 8, the spacing layer defining the channels having a thickness of about 50 μm . A non-coined Hostafilon film layer is then applied as the second base layer to complete the structure. This latter film has preferably been heat/pressure treated as above between flat silicon plates to provide a smooth contact surface. Optional liquid communication apertures (indicated as 14 in Fig. 5) are then drilled.

Fig. 9 illustrates the base layer/spacing layer unit 21, 22 of Fig. 8 inserted between clamping members 24, 25 to provide for efficient sealing between the components 21, 22 and 23, respectively. The upper clamping member 24

comprises a container recess 26 communicating with the spacing layer channel 22 through an aperture 27 for the introduction of a fluid into the channel, e.g. buffer in the case of an electrophoretic plate as outlined above in connection with Fig. 5.

It will be realized that in comparison with conventional capillary tube electrophoresis the electrophoretic plate according to the present invention offers several advantages. For example, it will be easy to provide branched inlets and outlets for the capillary structure, which in turn will permit such procedures as isotachophoretic concentration of the sample in a channel section at one end of the capillary channel structure, collection of fractions, and variation of connected electrolytes. Also preparative uses may be contemplated.

The electrophoretic plate having a capillary channel of rectangular cross-section as shown in the drawings and described above is further very advantageous from the viewpoint of detection. Thus, compared with conventional capillary tube electrophoresis it will be much easier to arrange various detector systems, one example being the conductivity detector mentioned above. Another example is the use of a UV detector. In that case the channel may be provided with one or more "windows", i.e. a UV transparent part of the channel bottom (in the illustrated cases base layer 1 or 1a). Such windows may be provided by e.g. metallizing a transparent base layer forming the bottom of the channel to leave a transparent opening or window at the desired site(s). Detection is then performed by illumination with a UV light source. By arranging a sequence of such windows at the inlet part of the channel the amount of sample injected may be determined. Optionally, detectors, such as UV detectors, may be arranged along the whole length of the channel, whereby the migration of the sample substance(s) in the channel may be monitored continuously. In an alternative arrangement a plurality of optical fibres opening towards the channel bottom may be used to direct the light to a detector array

for continuous monitoring of the whole or part of the channel. Other types of detectors are, of course, also possible. As is readily realized, the above described detection principles may also be of value for other applications than electrophoresis, such as e.g. chromatography.

Due to the resiliency of the spacing layer it will further be possible to provide for the injection of nanolitre quantity samples by a pumping action effected by varying the force that keeps the "sandwich" together. Also, the plate structure makes it possible to enrich sample molecules in an electrophoretic channel on a zone of e.g. an ion exchanger. An example of the provision of such an ion exchanger zone is given in Fig. 10 which illustrates an embodiment of a base layer corresponding to the base layer 1 in Figs. 1, 2 and 5. As shown in the figure, the base plate 28 has, in addition to detector electrodes 29, 30, a thin strip 31 of an ion exchanger material. When performing the electrophoresis with, for example, an electrophoretic plate according to Fig. 5, the strip 31 is within the channel 4, and sample in suitable buffer applied through the channel inlet is first enriched in ion exchanger strip 31. Electrophoretic buffer is thereupon introduced to remove the excess of sample in the channel 4. The sample is then desorbed by the electrophoretic field or the pH shift generated thereby.

Fig. 11 illustrates an electropherogram obtained in an electrophoresis of a restriction digest of ϕ X174 with Hae III performed with a Hostaflon electrophoretic plate produced as described above by coining against an etched silicon surface. The total channel length was 50 mm, the channel width was 250 μ m, and the channel height was 50 μ m. In use the plate was clamped between the flat surfaces of a clamping means with a total force of about 100 N. The separation channel was hydrophilized with a non-ionic detergent and filled with 10% linear polyacrylamide as separation media and Tris-borate, pH 8.3, was used as buffer. Injection was electrokinetic at 5 sec/700 V, total

potential drop 700 V. Detection was performed by UV at 260 nm.

The invention is, of course, not restricted to the specific embodiments described above and shown in the drawings, but many modifications and variations are within the scope of the general inventive concept as stated in the appended claims.

CLAIMS

1. A microfluidic structure, characterized in that it comprises first and second substantially planar form-stable base layers (1, 2), and an intermediate spacing layer (3) of elastic material, said spacing layer (3) being recessed to define a micro cavity or channel system (4) with at least one of said first and second base layers.
2. The structure according to claim 1, characterized in that said spacing layer (3) is recessed through the thickness thereof such that the side walls of the cavity or ~~channel system (4) are formed by the spacing layer (3) and~~ the top and bottom walls thereof are formed by the base layers (1, 2).
3. The structure according to claim 1 or 2, characterized in that the spacing layer and at least one base layer are made of the same material.
4. The structure according to claim 3, characterized in that the spacing layer is integral with one of the base layers (21).
5. The structure according to any one of claims 1 to 4, characterized in that at least one of said base layers (1, 2) is flexible.
6. The structure according to any one of claims 1 to 5, characterized in that at least one of said base layers (1, 2) is rigid.
7. The structure according to any one of claims 1 to 6, characterized in that the spacing layer structure (3) does not fill the whole space between the base layers but only forms wall members of the channel or cavity (4) defined by the structure.

8. The structure according to any one of claims 1 to 7, characterized in that said structure is a plate for capillary electrophoresis.

5 9. The structure according to claim 8, characterized in that it comprises detector means (7) arranged on one of the base layers (1, 2).

10 10. The structure according to any one of claims 1 to 9, characterized in that said structure comprises at least two spacing layers (3) separated by base layers (1, 2), the channels or cavities of one spacing layer being connected ~~to a channel or cavity of an adjacent layer by a bore in~~ the intermediate base layer.

15

11. A process of producing a microfluidic structure, said structure comprising first and second substantially planar form-stable base layers (1, 2), and an intermediate spacing layer (3) of elastic material, said spacing layer (3) being
20 recessed to define a micro cavity or channel system (4) with at least one of said first and second base layers, which process is characterized by the steps of (i) providing a planar mould surface having a relief pattern corresponding to the desired spacing layer geometry, the
25 spacing layer material optionally being attached to or integral with the first base layer (2), (ii) moulding the spacing layer (3) against said mould surface, and (iii) after removal from the mould applying the second base layer (1), and optionally said first base layer (2), to opposite
30 sides of the spacing layer (3) to complete the channel or cavity system (4) defined thereby.

12. The process according to claim 11, characterized by the steps of

- 35 a) providing a planar mould having a relief pattern corresponding to the desired spacing layer geometry;
b) applying a first base layer (2) against the mould;

- c) injecting a cross-linkable polymer liquid or thermoplastic polymer melt into the cavity defined between the mould surface and the base layer (2);
- d) stabilizing said injected polymer by cross-linking or temperature reduction;
- 5 e) removing the base layer/spacing layer assembly (2, 3) from the mould; and
- f) applying a second base layer (1) to the spacing layer (3) of said assembly (2, 3) .

10

13. The process according to claim 11, characterized by the steps of

- ~~a) providing a planar mould having a relief pattern~~
corresponding to the desired spacing layer geometry;
- 15 b) applying a cross-linkable or thermoplastic spacing layer material, optionally supported by or integral with a first base layer (2), against the mould and pressing the assembly together, optionally with heating;
- c) stabilizing the spacing layer (3) formed by cross-
- 20 linking or temperature reduction;
- d) removing the spacing layer structure from the mould; and
- e) applying a second base layer (1), and optionally said first base layer (1), to the spacing layer (3).

25 14. The process according to claim 13, characterized in that an integral base layer/spacing layer member is produced in steps b) and c).

15. The process according to any one of claims 12 to 14,
30 characterized in that said cross-linking is effected by photo-initiation.

16. The process according to any one of claims 11 to 15,
35 characterized in that said relief pattern of the mould surface is produced by etching.

17. The process according to claim 16, characterized in that said mould is made of single-crystalline silicon.

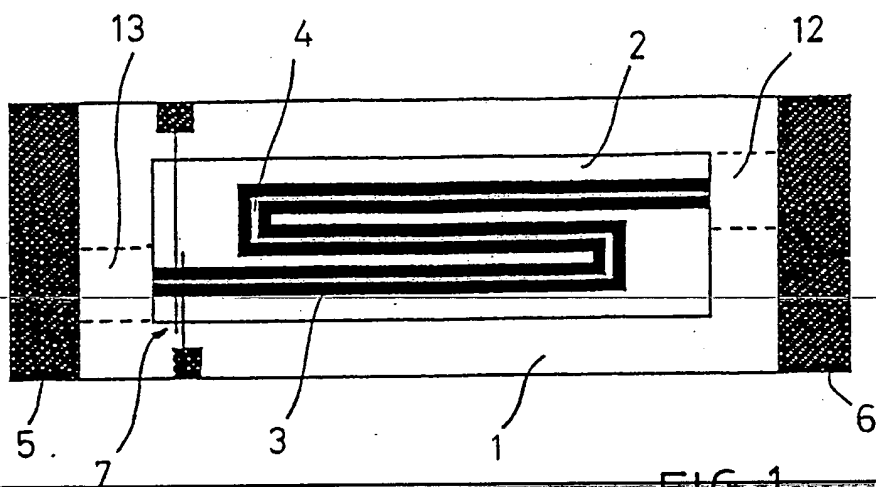

FIG. 1

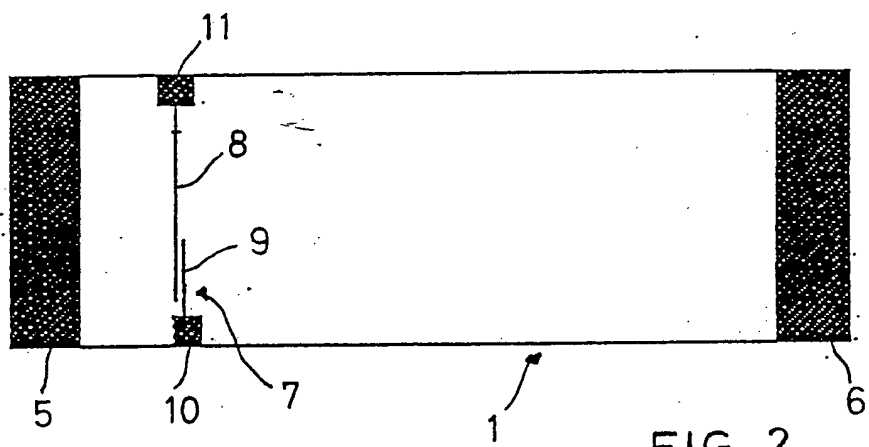

FIG. 2

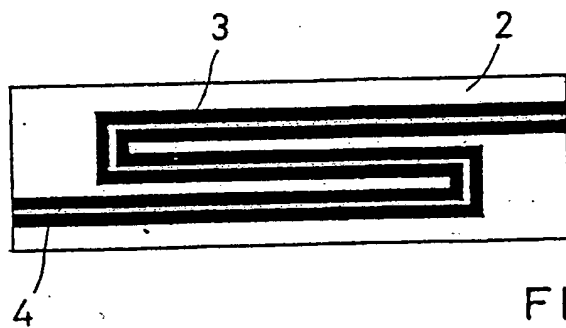

FIG. 3

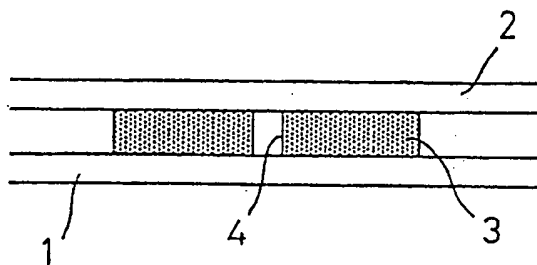

FIG. 4

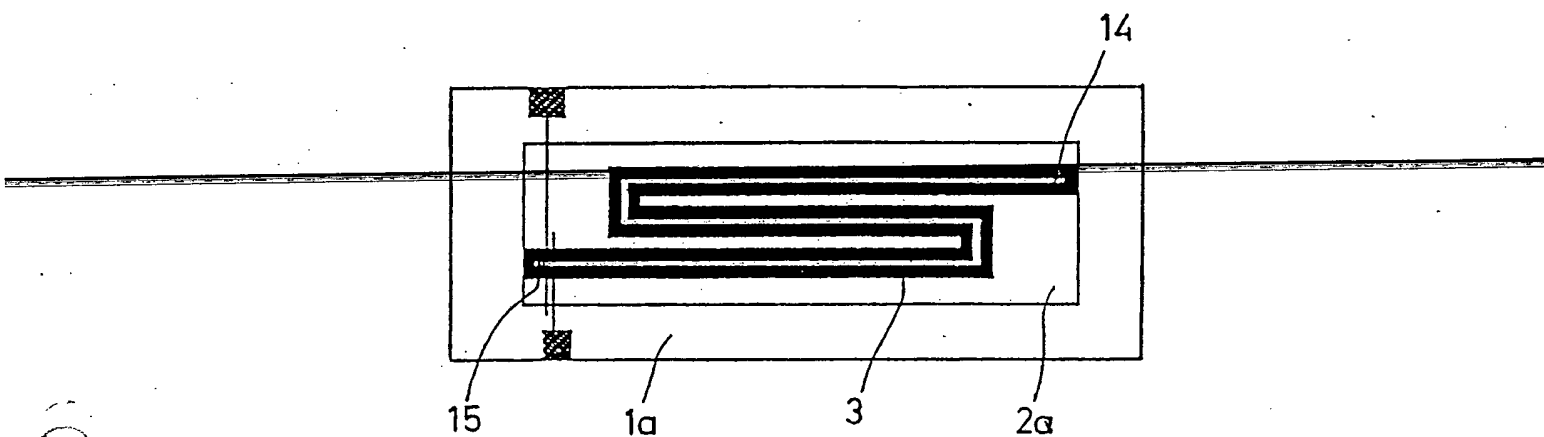

FIG. 5

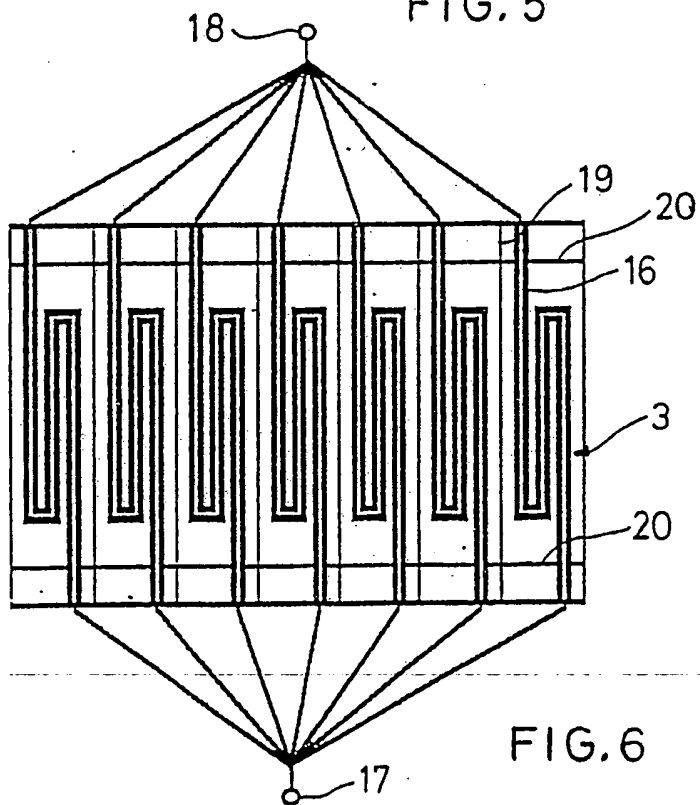

FIG. 6

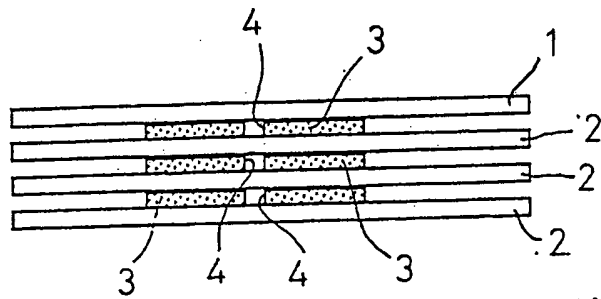

FIG. 7A

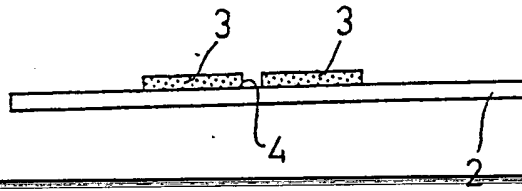

FIG. 7B

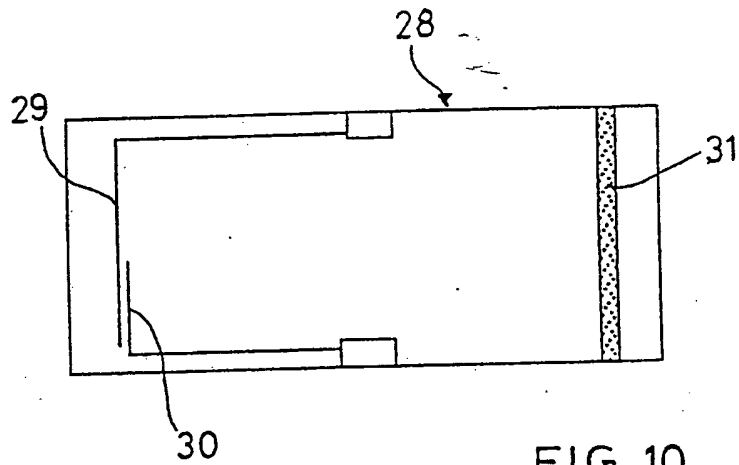

FIG. 10

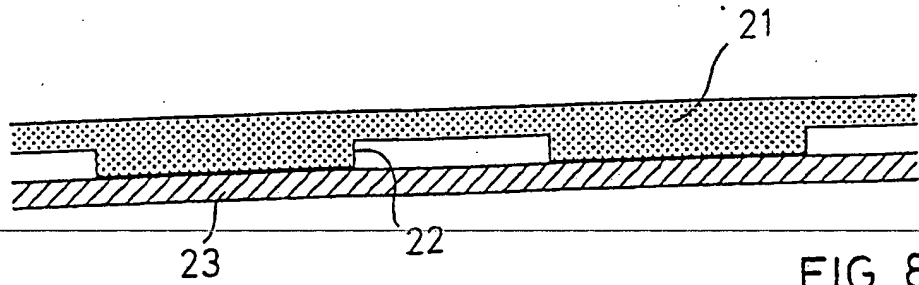

FIG. 8

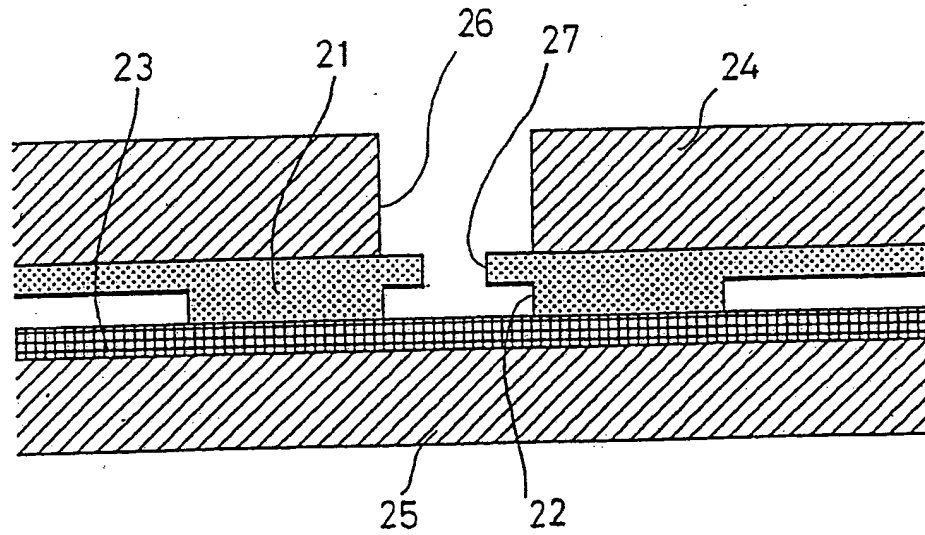

FIG. 9

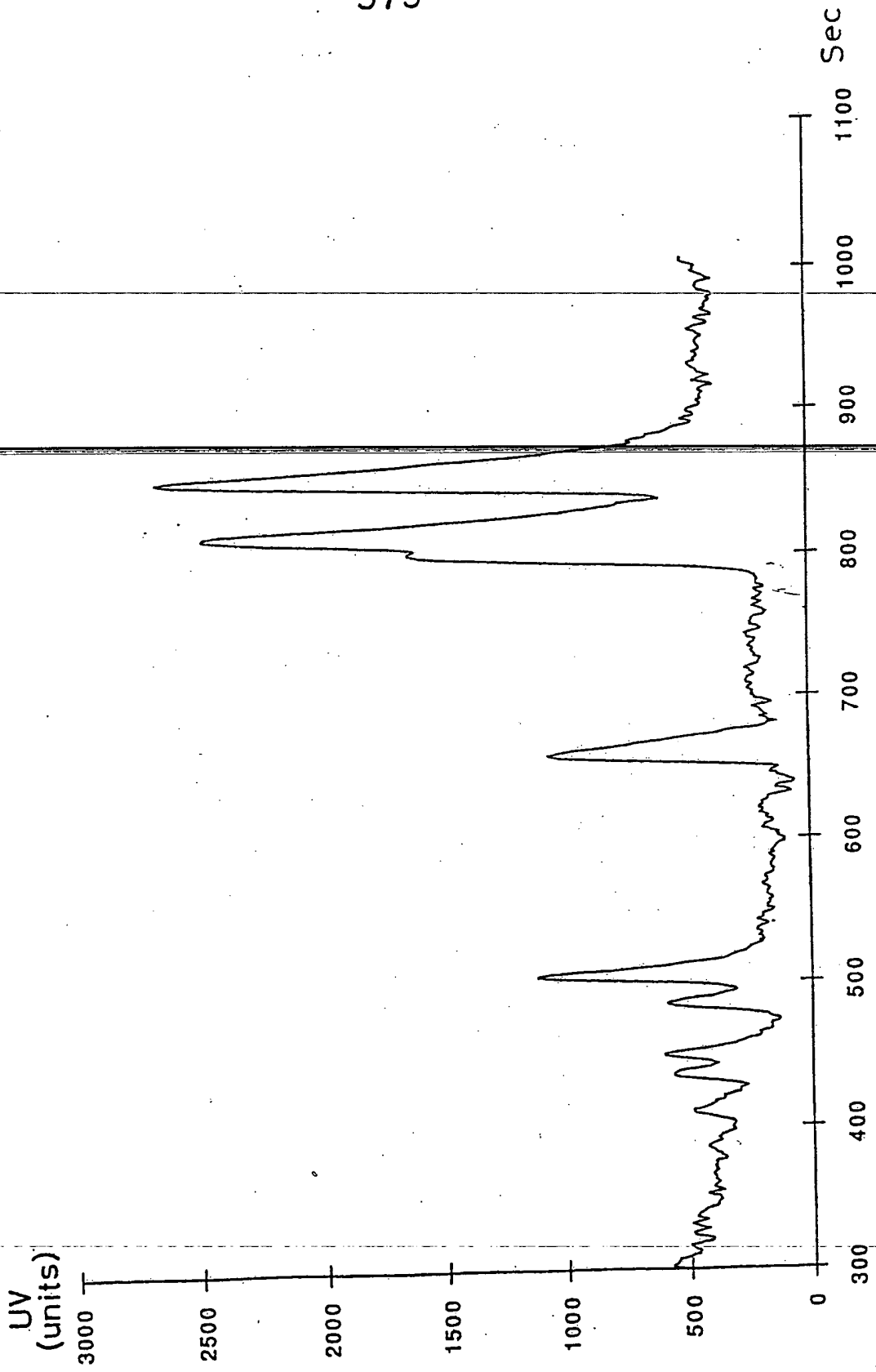



FIG. 11

INTERNATIONAL SEARCH REPORT

International Application No **PCT/SE 91/00327**

I. CLASSIFICATION OF SUBJECT MATTER (If several classification symbols apply, indicate all) ⁶		
According to International Patent Classification (IPC) or to both National Classification and IPC		
IPC5: B 01 D 57/02, G 01 N 27/26, B 01 L 3/00		
II. FIELDS SEARCHED		
Minimum Documentation Searched ⁷		
Classification System	Classification Symbols	
IPC5	G 01 N; B 01 L; B 01 D; B 29 C	
Documentation Searched other than Minimum Documentation to the Extent that such Documents are Included in Fields Searched ⁸		
SF,DK,FI,NO classes as above		
III. DOCUMENTS CONSIDERED TO BE RELEVANT⁹		
Category *	Citation of Document, ¹¹ with indication, where appropriate, of the relevant passages ¹²	Relevant to Claim No. ¹³
A	EP, A1, 0010456 (EASTMAN KODAK COMPANY) 30 April 1980, see the whole document --	1-17
A	US, A, 4900663 (S.I. WIE ET AL) 13 February 1990, see figure 4 --	1-17
A	EP, A2, 0347579 (MESSERSCHMITT-BÖLKOW-BLOHM GESELLSCHAFT MIT BESCHRÄNKTER HAFTUNG) 27 December 1989; see page 3, column 4, line 3 - line 26; figure 6 --	1-17
A	EP, A2, 0107631 (BIFOK AB ET AL) 2 May 1984, see page 5, line 20 - page 6, line 6; figure 1 -- -----	1-17
<p>¹⁰ Special categories of cited documents:</p> <p>"A" document defining the general state of the art which is not considered to be of particular relevance</p> <p>"E" earlier document but published on or after the international filing date</p> <p>"L" document which may throw doubts on priority claim(s) or which is cited to establish the publication date of another citation or other special reason (as specified)</p> <p>"O" document referring to an oral disclosure, use, exhibition or other means</p> <p>"P" document published prior to the international filing date but later than the priority date claimed</p> <p>"T" later document published after the international filing date or priority date and not in conflict with the application but cited to understand the principle or theory underlying the invention</p> <p>"X" document of particular relevance, the claimed invention cannot be considered novel or cannot be considered to involve an inventive step</p> <p>"Y" document of particular relevance, the claimed invention cannot be considered to involve an inventive step when the document is combined with one or more other such documents, such combination being obvious to a person skilled in the art</p> <p>"&" document member of the same patent family</p>		
IV. CERTIFICATION		
Date of the Actual Completion of the International Search	Date of Mailing of this International Search Report	
9th July 1991	1991-07-30	
International Searching Authority	Signature of Authorized Officer	
SWEDISH PATENT OFFICE	 Inger Löfgren	

ANNEX TO THE INTERNATIONAL SEARCH REPORT
ON INTERNATIONAL PATENT APPLICATION NO. PCT/SE 91/00327

This annex lists the patent family members relating to the patent documents cited in the above-mentioned international search report. The members are as contained in the Swedish Patent Office EDP file on 91-05-29
The Swedish Patent Office is in no way liable for these particulars which are merely given for the purpose of information.

Patent document cited in search report	Publication date	Patent family member(s)	Publication date
EP-A1- 0010456	80-04-30	AT-T- 1366	82-08-15
		CA-A- 1129498	82-08-10
		US-A- 4254083	81-03-03
		AT-T- 4249	83-08-15
		CA-A- 1119831	82-03-16
		CA-A- 1133059	82-10-05
		EP-A-B- 0010457	80-04-30
		EP-A-B- 0014797	80-09-03
		JP-C- 1196515	84-03-21
		JP-C- 1248146	85-01-16
		JP-A- 55059326	80-05-02
		JP-A- 55071942	80-05-30
		JP-A- 55074462	80-06-05
		JP-B- 58026968	83-06-06
JP-B- 59021501	84-05-21		
US-A- 4233029	80-11-11		
US-A- 4900663	90-02-13	AU-B- 594942	90-03-22
		AU-D- 5443286	87-03-19
		BE-A- 904395	86-06-30
		CA-A- 1258626	89-08-22
		CH-A-B- 671 . . .	89-08-31
		DE-A- 3606124	87-03-19
		FR-A- 2587488	87-03-20
		GB-A-B- 2180645	87-04-01
		JP-A- 62071832	87-04-02
		NL-A- 8600305	87-04-01
		SE-A- 8600454	87-03-14
EP-A2- 0347579	89-12-27	DE-A- 3818614	89-12-07
		DE-A- 3825907	90-02-01
EP-A2- 0107631	84-05-02	JP-A- 59083047	84-05-14